

5. Boundary Dimensions and Bearing Number Codes

5.1 Boundary dimensions

A rolling bearing's major dimensions, known as "boundary dimensions," are shown in **Figs. 5.1 - 5.3**. To facilitate international bearing interchangeability and economical bearing production, bearing boundary dimensions have been standardized by the International Standards Organization (ISO). In Japan, rolling bearing boundary dimensions are regulated by Japanese Industrial Standards (JIS B 1512).

Those boundary dimensions which have been standardized include: bearing bore diameter, outside diameter, width/height, and chamfer dimensions - all important dimensions when considering the compatibility of shafts, bearings, and housings. However, as a general rule,

bearing internal construction dimensions are not covered by these dimensions.

For metric series rolling bearings there are 90 standardized bore diameters (d) ranging in size from 0.6mm - 2,500mm.

Outer diameter dimensions (D) for radial bearings with standardized bore diameter dimensions are covered in the "diameter series;" their corresponding width dimensions (B) are covered in the "width series." For thrust bearings there is no width series; instead, these dimensions are covered in the "height series." The combination of all these series is known as the "dimension series." All series numbers are shown in **Table 5.1**.

Although many rolling bearing dimensions are standardized, and have been listed here for purposes of

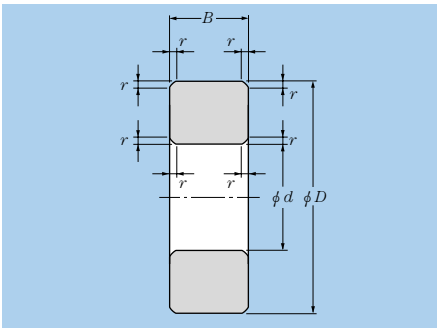

Fig. 5.1 Radial bearings (excluding tapered roller bearings)

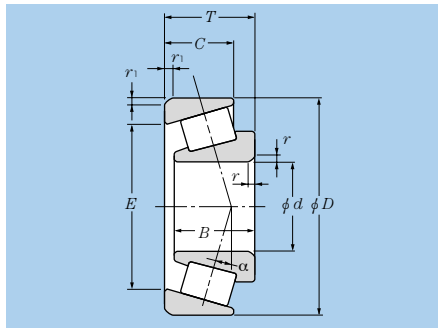

Fig. 5.2 Tapered roller bearings

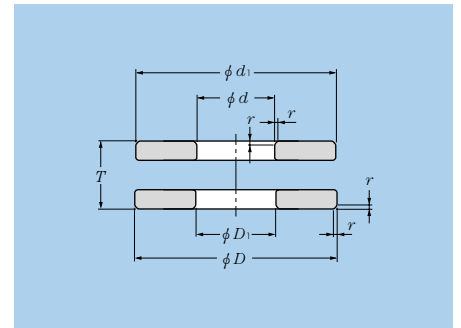

Fig. 5.3 Single direction thrust bearings

Table 5.1 Dimension series numbers

	Dimension series				Reference diagram
		Diameter series (outer diameter dimensions)	Width series (width dimensions)	Height series (height dimensions)	
Radial bearings (excluding tapered roller bearings)	number	7, 8, 9, 0, 1, 2, 3, 4	8, 0, 1, 2, 3, 4, 5, 6	—	Diagram 5.4
	dimensions	small ← → large	small ← → large	—	
Tapered roller bearings	number	9, 0, 1, 2, 3	0, 1, 2, 3	—	Diagram 5.5
	dimensions	small ← → large	small ← → large	—	
Thrust bearings	number	0, 1, 2, 3, 4	—	7, 9, 1, 2	Diagram 5.6
	dimensions	small ← → large	—	small ↔ large	

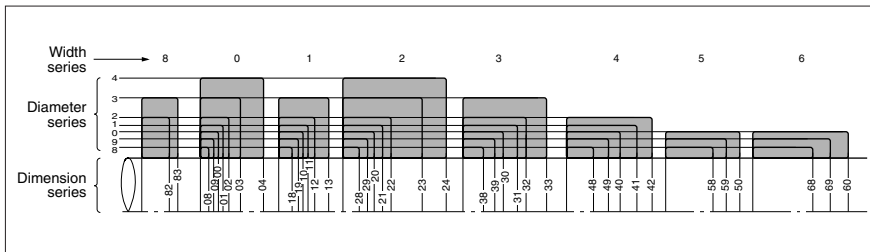

Fig. 5.4 Dimension series for radial bearings (excluding tapered roller bearings; diameter series 7 has been omitted)

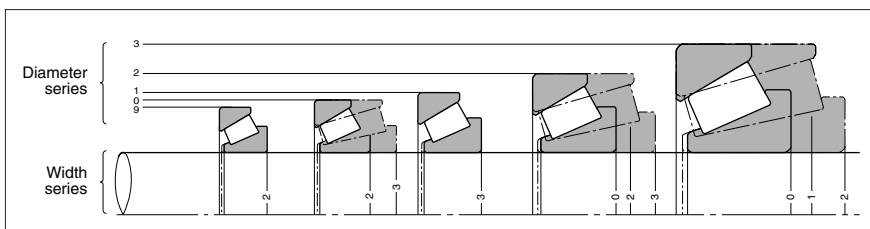

Fig. 5.5 Dimension series for tapered roller bearings

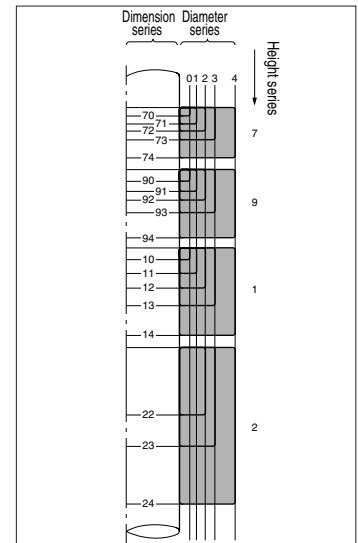

Fig. 5.6 Dimension series for thrust bearings (excluding diameter series 5)

future standardization, there are many standard bearing dimensions which are not presently manufactured.

Boundary dimensions for radial bearings (excluding tapered roller bearings) are shown in the attached tables.

5.2 Bearing numbers

Rolling bearing part numbers indicate bearing type, dimensions, tolerances, internal construction, and other related specifications. Bearing numbers are comprised of a

"basic number" followed by "supplementary codes." The makeup and order of bearing numbers is shown in **Table 5.2**.

The basic number indicates general information about a bearing, such as its fundamental type, boundary dimensions, series number, bore diameter code and contact angle. The supplementary codes derive from prefixes and suffixes which indicate a bearing's tolerances, internal clearances, and related specifications.

(Bearing number examples)

6205ZZC3 / 2AS

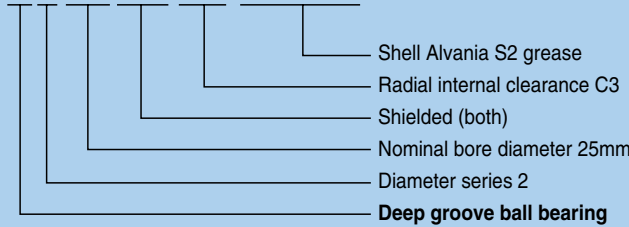

23034BD1

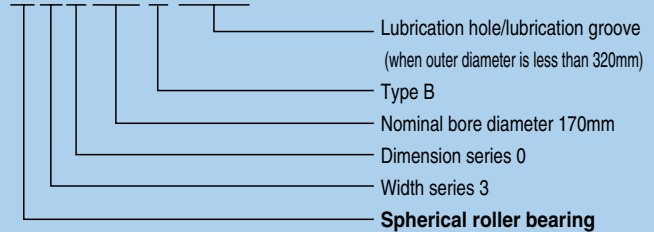

7012BDB / GMP6

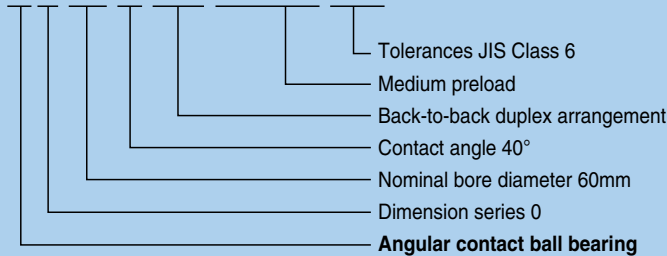

240 / 750BK30

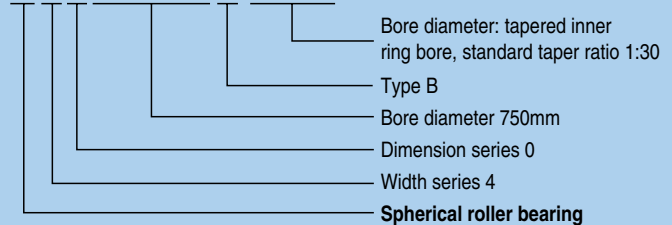

NU320G1C3

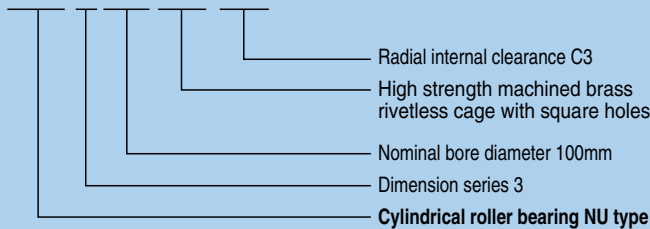

51120L1P5

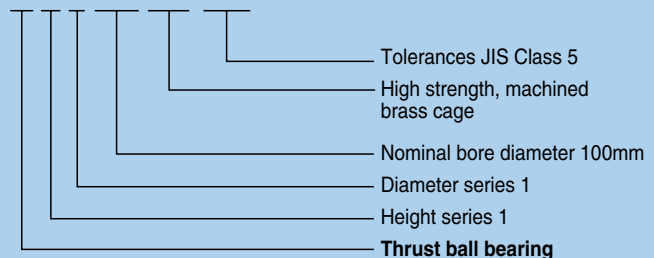

4T - 30208



Table 5.2 Bearing number composition and arrangement

Supplementary prefix code Special application/material/ heat treatment code	Basic number						
	Bearing series			Bore diameter code		Contact angle code	
	Bearing series code	Dimension series code		Code	bore diameter mm	Code ^①	Contact angle
Width/height series ^①		Diameter series					
4T: 4T tapered roller bearings	Deep groove ball bearings (type code 6)			/0.6	0.6	Angular contact ball bearings	
ET: ET tapered roller bearings	68	(1)	8	/1.5	1.5	(A)	Standard contact angle 30°
ETA: ET+special heat treatment	69	(1)	9	/2.5	2.5	B	Standard contact angle 40°
E: Bearing using case hardened steel	60	(1)	0			C	Standard contact angle 15°
EA: Bearing made of nitride-treated case hardened steel	62	(0)	2	1	1	Tapered roller bearings	
TA: Bearing made of nitride-treated bearing steel (SUJ3)	63	(0)	3	:	:	(B)	Contact angle over 10°
	Angular contact ball bearings (type code 7)			9	9	C	to/including 17°
	78	(1)	8	00	10	D	Contact angle over 17°
	79	(1)	9	01	12		to/including 24°
	70	(1)	0	02	15		Contact angle over 24°
	72	(0)	2	03	17		to/including 32°
	73	(0)	3				
	Self-aligning ball bearings (type code 1,2)						
	12	(0)	2				
	13	(0)	3				
	Cylindrical roller bearings (type code NU, N, NF, NNU, NN, etc.)						
	22	(2)	2	/22	22		
	23	(2)	3	/28	28		
				/32	32		
	NU10	1	0	04	20		
	NU2	(0)	2	05	25		
	NU22	2	2	06	30		
	NU3	(0)	3	:	:		
	NU23	2	3	88	440		
	NU4	(0)	4	92	460		
	NNU49	4	9	96	480		
	NN30	3	0				
	Tapered roller bearings (type code 3)						
	329X	2	9	/500	500		
	320X	2	0	/530	530		
	302	0	2	/560	560		
	322	2	2	:	:		
	303	0	3	/2,360	2,360		
	303D	0	3	/2,500	2,500		
	313X	1	3				
	323	2	3				
	Spherical roller bearings (type code 2)						
	239	3	9				
	230	3	0				
	240	4	0				
	231	3	1				
	241	4	1				
	222	2	2				
	232	3	2				
	213	1	3				
	223	2	3				
	Single direction thrust ball bearings (type code 5)						
	511	1	1				
	512	1	2				
	513	1	3				
	514	1	4				
	Cylindrical roller thrust bearings (type code 8)						
	811	1	1				
	812	1	2				
	893	9	3				
	Spherical thrust roller bearings (type code 2)						
	292	9	2				
	293	9	3				
	294	9	4				

① Codes in () are not shown in nominal numbers.

Note: Please consult NTN Engineering concerning bearing series codes, and supplementary prefix/suffix codes not listed in the above table.

Supplementary suffix codes							
Internal modifications code	cage code	Seal / Shield code	External configuration code	Duplex arrangement code	Internal clearance /preload code	Tolerance code	Lubrication code
U: Internationally interchangeable tapered roller bearings	L1: High strength, machined brass cage	LLB: Synthetic rubber seal (non-contact type)	K: Tapered inner ring bore, standard taper ratio 1:12	DB: Back-to-back arrangement	C2: Internal clearance less than normal	P6: JIS Class 6	/2AS: Shell Alvania S2 grease
R: Non-internationally interchangeable tapered roller bearings	F1: Machined carbon steel cage	LLU: Synthetic rubber seal (contact type)	K30: Tapered inner ring bore, standard taper ratio 1:30	DF: Face-to-face arrangement	(CN): Normal clearance	P5: JIS Class 5	/3AS: Shell Alvania S3 grease
ST: Low torque tapered roller bearings	G1: High strength machined brass rivetless cage with square holes,	LLH: Synthetic rubber seal (low-torque type)	N: With snap ring groove	DT: Tandem arrangement	C3: Internal clearance greater than normal	P4: JIS Class 4	/8A: Shell Alvania EP2 grease
HT: High axial load use cylindrical roller bearings	G2: Pin type cage	ZZ: Steel shield	NR: With snap ring	D2: Two matched, paired bearings	C4: Internal clearance greater than C3	2: ABMA Class 2	/5K: MULTEMP SRL
J: Pressed steel cage	J: Pressed steel cage		D: With oil hole	G: Flush ground	C5: Internal clearance greater than C4	3: ABMA Class 3	/LX11: Barierta JFE552
T2: Plastic mold cage	T2: Plastic mold cage		D1: Lubrication hole/lubrication groove	+ α : Spacer (α = spacer's standard width dimensions)	CM: Radial internal clearance for electric motor use	0: ABMA Class 0	/LP03: Thermosetting grease (grease for poly-lube bearings)
					/GL: Light preload	00: ABMA Class 00	
					/GN: Normal preload		
					/GM: Medium preload		
					/GH: Heavy preload		